

extrusion & compounding

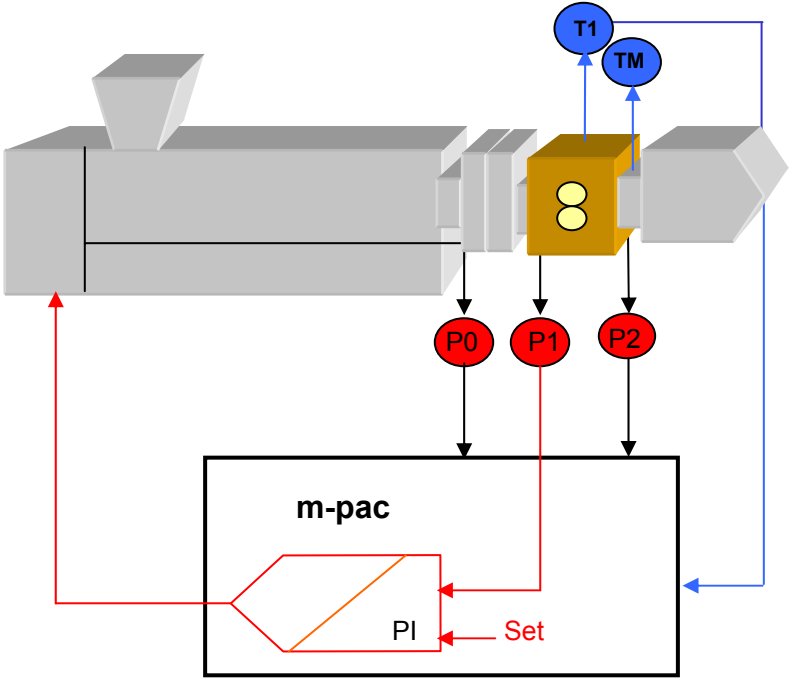

control and power unit	
M1	
features:	
pressure controller (p1) with auto cut-in function	
pressure indicator (p2)	
temperature controller (pump)	
melt temperature indicator	
pump speed indicator	
pump current indicator	
extruder speed indicator	
extruder current indicator	
trend graphics	
automatic start and shut off ramp	
optional features:	
filter control	
Digital In / Output:	0 / 24VDC
Analog In / Output:	0 - 10VDC
power supply:	400V 50Hz 3ph. N + Gr.
ambient temp.:	+5 - +55°C
installation:	internal, w/o aggressive agents and rel. humidity of < 80%, w/o condensation
execution:	according actual CE standards
dimensions (mm):	800 (L) x 600 (B) x 2200 (H)

control and power unit	
IT1	
features:	
pressure controller (p1)	
pressure indicator (p2)	
temperature controller (pump)	
melt temperature indicator	
pump speed indicator	
pump current indicator	
extruder speed indicator	
extruder current indicator	
optional features:	
filter control	
Digital In / Output:	0 / 24VDC
Analog In / Output:	0 - 10VDC
power supply:	400V 50Hz 3ph. N + Gr.
ambient temp.:	+5 - +55°C
installation:	internal, w/o aggressive agents and rel. humidity of < 80%, w/o condensation
execution:	according actual CE standards
dimensions (mm):	1200 (L) x 400 (B) x 1350 (H)

switch to eprotec-extrusion.com



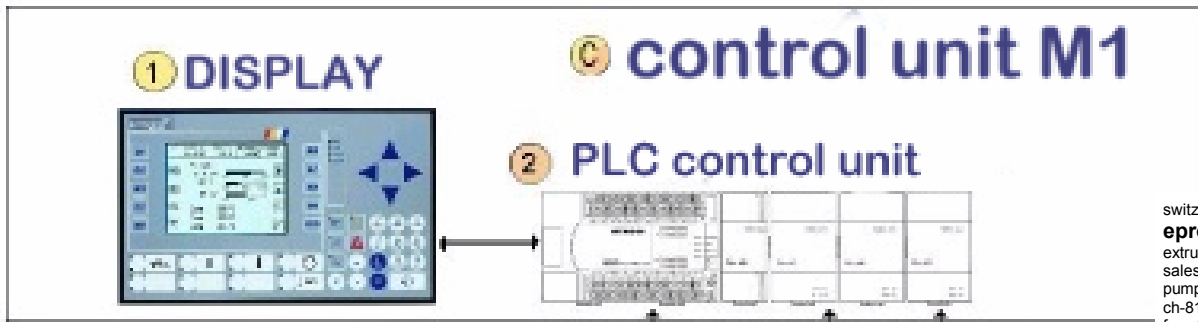

switzerland:
eptotec
 extrusion technology AG
 sales and service
 pumpwerkstrasse 23
 ch-8105 regensdorf
 fon: +41 43 388 90 90
 fax: +41 43 388 90 99
 info@eptotec-extrusion.com
 www.eptotec-extrusion.com

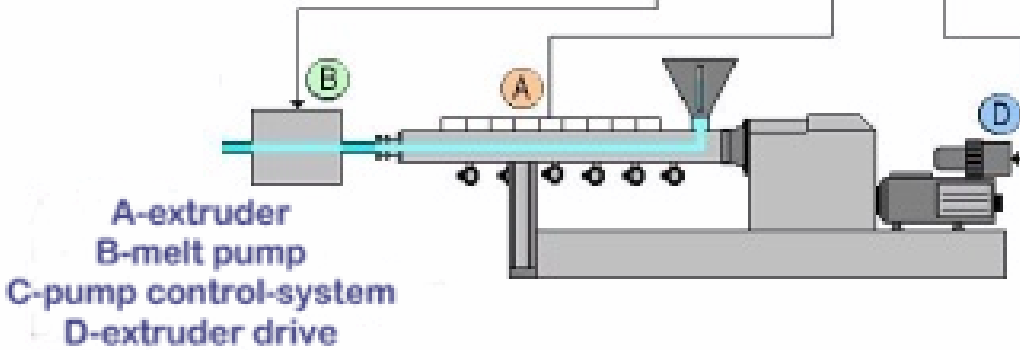

italy:
Soconomar SpA
 Marco de Michelis
 Viale Romagna 14
 i-20133 Milano
 fon: +39 02 761 07 44
 fax: +39 02 761 103 36
 m.demichelis@soconomar.it

germany and austria:
AH EXTRUSION
 andreas huemer
 hochpointstrasse 13
 a-4600 wels
 fon: +43 7242 60649
 fax: +43 7242 207130
 huemer@extrusion.at

for thermoplastic applications

netherlands:
Plettenburg
Technisch Bureau
 Bedrijvenstraat 3
 7641 AM Vierden
 fon: +31 546 57 21 83
 fax: +31 546 57 31 05
 info@plettenburg.com

poland:
fuh „sabat“
jacek sabat
 ul. prugara-ketlinga 4/33
 pl-38-500 sanok
 fon: +48 13 463 49 58
 fax: +48 13 463 49 58
 jaceksabat@hotmail.com

turkey:
EN KO
 hasan dsnen
 bakir—pirin sanayi sitesi
 meneke cad. No: 8
 beylikdz-istanbul / turkey
 fon: +90 212 875 5915
 fax: +90 212 875 5922
 Hasan.dusunen@enkomakine.com

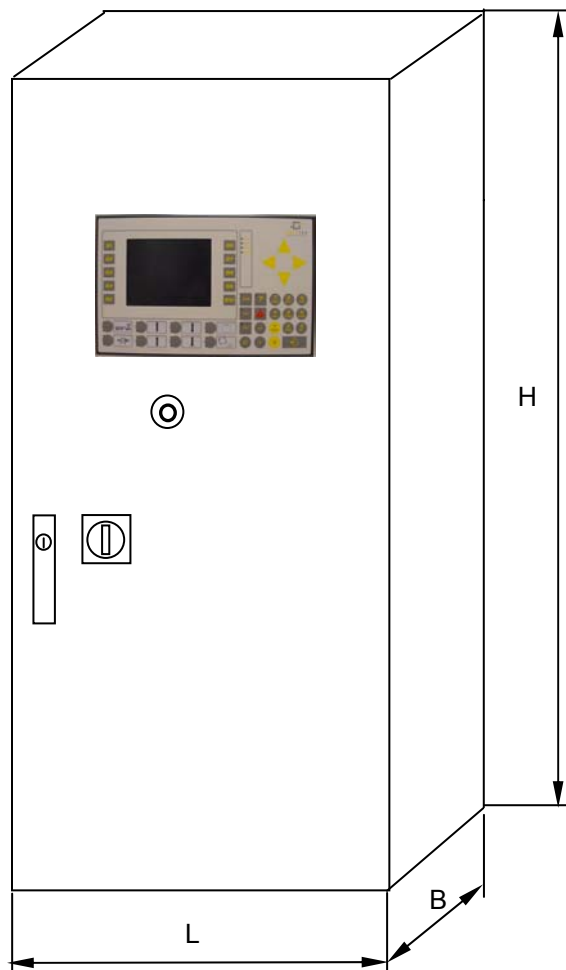

www.eptotec-extrusion.com
 info@eptotec-extrusion.com



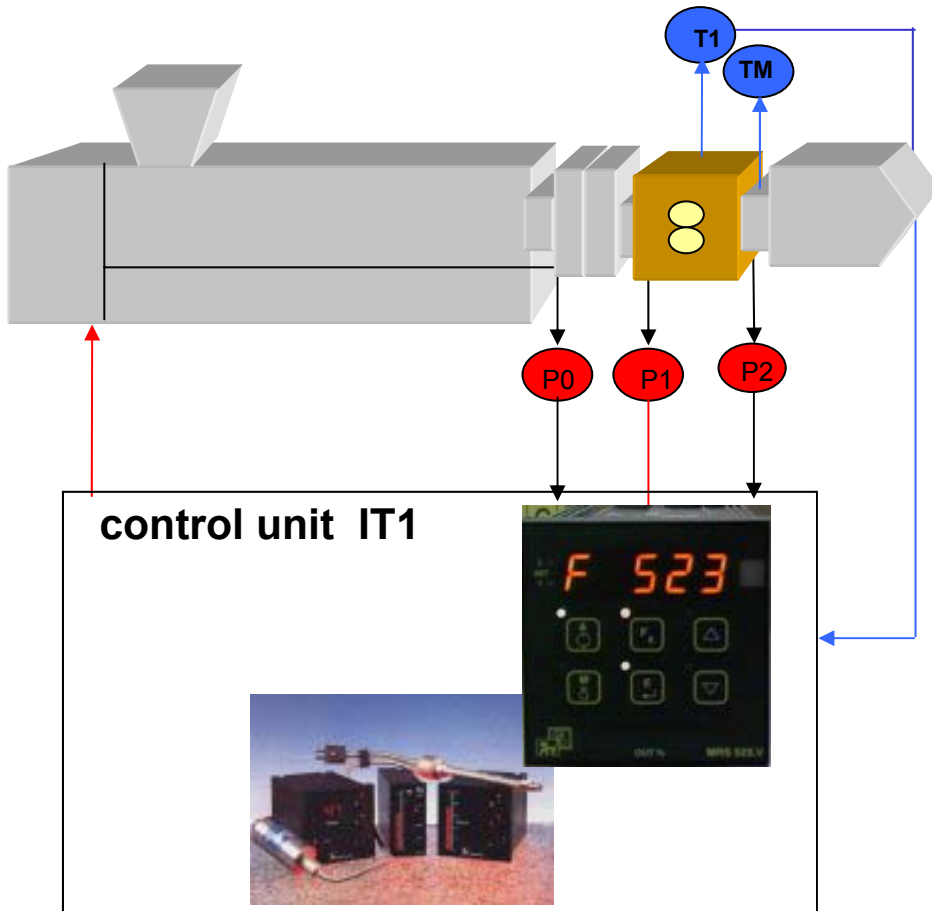

switzerland:
eprotec
 extrusion technology AG
 sales and service
 pumpwerkstrasse 23
 ch-8105 regensdorf
 fon: +41 43 388 90 90
 fax: +41 43 388 90 99
 info@eprotec-extrusion.com
 www.eprotec-extrusion.com

italy:
Soconomar SpA
 marco de michelis
 viale romagna 14
 i-20133 milano
 fon: +39 02 761 07 44
 fax: +39 02 761 103 36
 m.demichelis@soconomar.it

germany and austria:
AH EXTRUSION
 andreas huemer
 hochpointstrasse 13
 a-4600 wels
 fon: +43 7242 60649
 fax: +43 7242 207130
 huemer@extrusion.at

for thermoplastic applications

netherlands:
Plettenburg
Technisch Bureau
 bedrijvenstraat 3
 7641 AM wierden
 fon: +31 546 57 21 83
 fax: +31 546 57 31 05
 info@plettenburg.com

poland:
fuh „sabat“
jacek sabat
 ul. prugara-ketlinga 4/33
 pl-38-500 sanok
 fon: +48 13 463 49 58
 fax: +48 13 463 49 58
 jaceksabat@hotmail.com

turkey:
EN KO
 hasan düşünen
 bakır—pirinç sanayi sitesi
 menekşe cad. No: 8
 beylikdüzü-istanbul / turkey
 fon: +90 212 875 5915
 fax: +90 212 875 5922
 hasan.dusunen@enkomakine.com

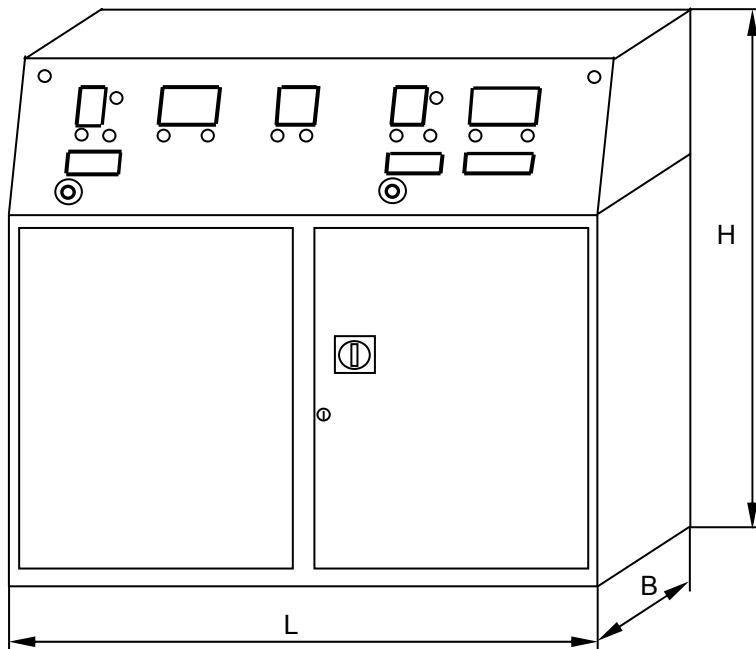

www.eprotec-extrusion.com
 info@eprotec-extrusion.com

